



Wavelength
ENGINEERING WATER

AquaWave

EPS-203

Phone: 027 687 7702
2/36 Zelanian Drive, East Tamaki, Auckland 2013
www.wavelengthwater.co.nz



Description

AquaWave whole house UV system is an advanced whole house water treatment system.

 The unit delivers complete water treatment in 3 stages, two staged sediment filtration and a UV purification stage removing bacteria and pathogens whilst improving taste, clarity and odour.

Features & Benefits

- Makes water in the home safe to drink including bathrooms and showers.
- Compact wall-mounted bracket design making installation a breeze with rain resistant cover.
- Natural chemical free process.
- Low maintenance system requiring replacement lamp every 12 months.
- 304 Stainless steel reactor and connection hose.
- Digital controller with display
- Pre-assembled L-R and R-L option for quick “plug and play” installations.
- Pressure gauge.
- Stylish design.

Protects against

- Pathogen protection including E Coli, Cryptosporidium & Giardia so it's safe to drink.
- Removes sediment.
- Premium filter housings with PS & PP sediment filter cartridges (carbon available).
- Bacteria, Viruses (Chlorine taste & Odour), sediment and Cysts



Typical Applications

- Domestic Homes
- Tiny Homes



Certifications:

- EC RoHS
- {{Certification 2}}

EPS whole house UV system Recommended by professional installers.

- First line defense to your appliances. It protects and extends the life of your standard filters.
- Protect your entire plumbing system from sediment, rust, dirt, sand, and large particles. Flushable and reusable takes the considerable workload off finer filters that follow behind it.
- Easy installation.

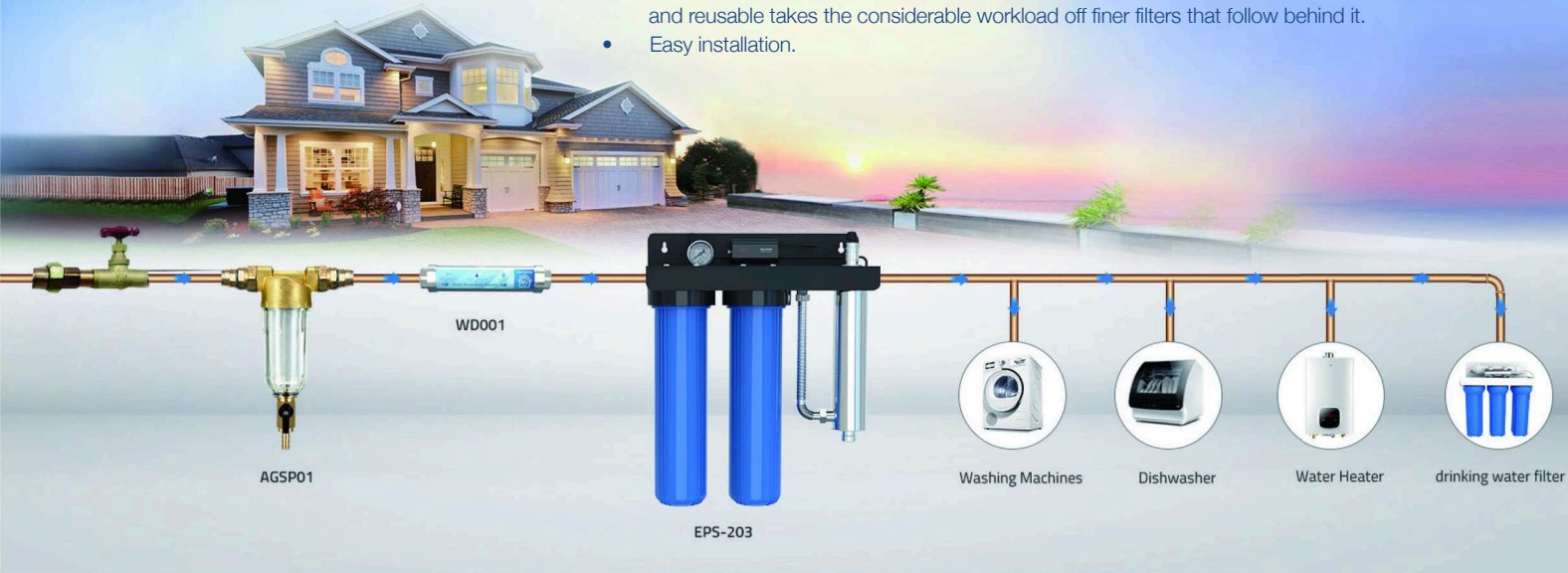

Specifications

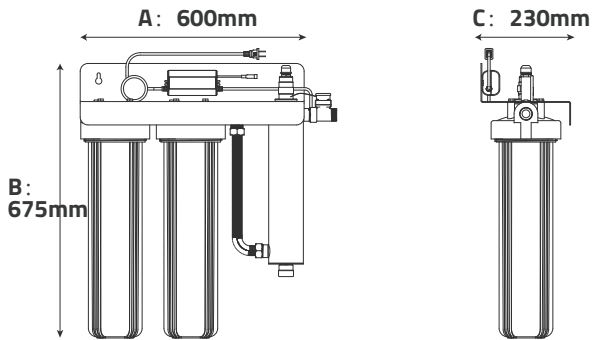

Model	Dimensions			UV Dose Flow Rates		
	A	B	C	16mj/cm ²	30mj/cm ²	40mj/cm ²
EPS-203	600	675	230	78lpm(20GPM)	45lpm(12GPM)	31lpm(8GPM)

	Inlet	Outlet	1st Stage	2nd Stage	UV Lamp	Maximum Pressure
	1" Female	1" Male	1 micron sediment filter (20*4.5")	Carbon Filter (20*4.5")	48W	10bar

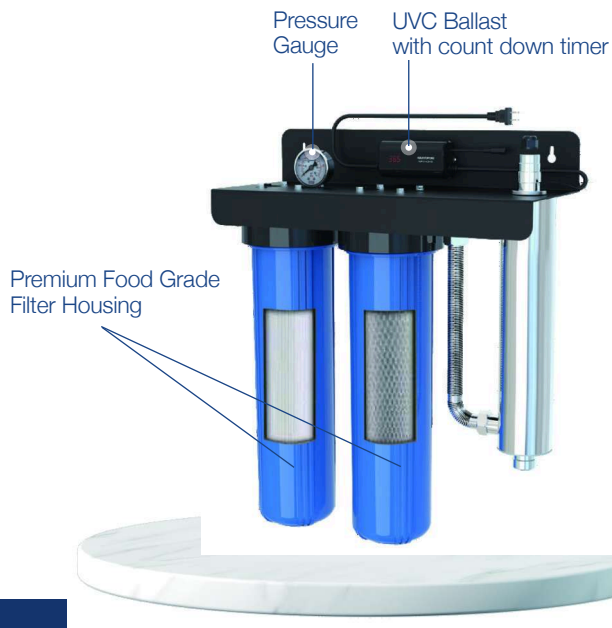

Warranty

(refer to Owner's Manual for complete details including conditions & exclusions):

Reactor Chamber: 3 (three) Years

UV Lamps: 30 days against manufacturing defects

Limited Electronics: 1 (one) Year Limited

Quartz Sleeves: 30 days against manufacturing defects