



TECHNICAL DATA SHEET:

SLIMLINE WATER TANKS

The TANKSALOT® Water Slimline range of Water Tanks are available in a range of popular colours and in a range of made to measure sizes up to 10,000 litres. They are built for narrow spaces, usually to fit along the side of your house. Internal stainless steel cross bracing is engineered into the tank for maximum durability and strength.



Features & Benefits

- › Made to measure
- › Made with AQUAPLATE® steel
- › 20 year Corrosion Warranty & 10 year Construction Warranty
- › Option to nominate fitting positions for Tank Inlet, Overflow and Outlet
- › Food grade polymer preventing any water to metal contact
- › Rigid cross bracing system, won't bulge or bow
- › Henrob riveting system for functional superiority
- › Rivets sit flush against tank
- › Modern look
- › Capacity up to 10,000L
- › Can be placed onto a concrete pad or an engineered timber platform
- › Available in hundreds of sizes
- › New Zealand made
- › Planet friendly – smallest environmental footprint
- › Available in a range of Colorbond® colours

Recommended For

- › Small narrow spaces, designed to fit alongside dwellings
- › Aesthetical modern design to blend with architectural features of dwellings
- › Storage of drinking water - AS4020 NZS3500
- › The New Zealand climate
- › Potable or non-potable water systems

Inclusions

- › 25mm Outlet
- › 90mm or 100mm Overflow
- › 400mm Inlet & Light Guard with Mosquito Screen

Preparation

First fill of water in tanks should be discarded prior to use.

Location

If possible, locate the tank in a shady site away from trees to prevent debris clogging the strainer resulting in contamination of the water.



Tank Base

Tanks should not be placed directly onto the ground and must be installed on a firm, stable platform with no overhang of the tank over the edge of the base. For further information refer to TANKSALOT® Water Tank Base Preparation Guide.

Accessories

There are a range of accessories such as pumps, filters, level indicators, rain heads and stands that are available from TANKSALOT®.

Inlet Strainers

Anodised aluminium mesh or stainless is recommended for Inlet Strainers. Copper or copper alloys must not be used. Overflow diameter should match inflow pipe diameter. A PVC Overflow with appropriately contoured flanges or a stormwater pipe adaptor should be fitted.

Odour & Taste

Care should be taken to ensure that contaminants are not introduced into the water tank. In the event that any odour or taste is noticed, the catchment area should be checked for contaminants such as lichen or deceased animals as these are known to affect water quality. New tanks should be flushed out if slight odour or taste is present.

Quality Assurance

Tanks are water tested for structural integrity.

Warranty

TANKSALOT® offers this product under a 20 year Corrosion Warranty and 10 year Construction Warranty.

Physical Properties: Appearance – Made to Measure

Height	580mm – 2470mm
Width	550mm – 1150mm
Length	1200mm – 4000mm
Min Size	600 litres
Max Size	10,000 litres
Vertical Wall	Precision roll formed 0.6mm AQUAPLATE® steel
Base	Double sided AQUAPLATE® steel (internal & external polymer lining)
Lid	Colorbond® or Z450 grade material
Rivets V Tek Screws	Henrob self piercing rivets. Reinforced 6mm, grade 304 stainless steel tension rods
Sealing	Neutral cure silicone sealant potable water approved
Corrugations	Corrugations for the tank walls comply with AS1445
Corrosion protection	Z450 Galvanised, Z275 Colorbond®, Painted – Low VOC Acrylic type paint

AQUAPLATE® Steel

Thermal Resistance	Do not store water at temperatures in excess of 65°C
--------------------	--

Maximum durability

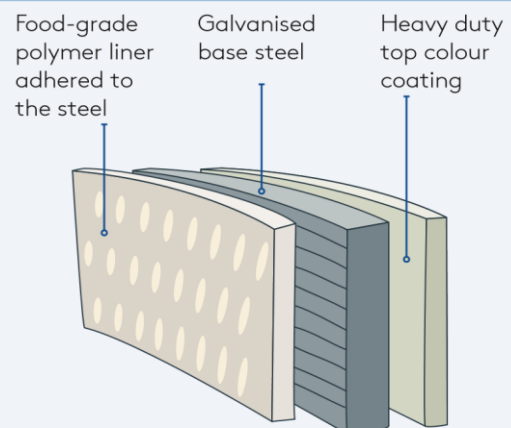

AQUAPLATE® and Colorbond® Steels are registered trade marks of Blue Scope Steel Limited.